

User Manual



WATER PURIFIERS



Customer Care: 1800 2585 710 / +91 89291 45710

CONTENTS

About BRITA	01	Draining the Drip Tray	26
Pre-instruction Literature	02	How to Maintain the water purifier	27
General Instructions	03	How to connect the water purifier and the App via Wi-Fi	29
Introduction	04	Troubleshooting	30
Working of the water purifier	06	Technical Specifications	32
Product Overview	11	Frequently Asked Questions	34
Function of Indicators	14	Recommended Uses of Waste Water	36
Working Diagrams	17	Recommended Filter Change	36
Safety Precautions	22	Warranty Policy	37
How to Use the water purifier	24	Warranty Card	42
How to Dispense Water	25		

Welcome



WATER PURIFIERS

Dear Customer

It gives me a great pleasure to welcome you to the exciting world of **BRITA**.

As a responsible individual myself, I am committed to ensuring that there is no compromise when it comes to my family's health. And this promise is what I would like to offer to you, as part of the growing BRITA customer family in India.

When you choose BRITA, you have the assurance and reliability of **German engineered water purifier**. Having honed our knowledge in providing drinking water solutions, we have researched the Indian water conditions for over two years to provide the right solutions for the Indian consumer, with our German engineering expertise and our understanding of local market. BRITA is dedicated to deliver **Max Performance, Max Quality and Max Reliability** with BRITA Mypure Max, an innovative 100% RO+UV water purifier.

At BRITA, we aspire every day to perfect our drinking water solutions to make India healthier and more sustainable.

Our commitment to your family's health means that we aim to be there with you every step of the way. Simply dial **1800 2585 710 / +91 89291 45710** for any queries or questions you may have. My team and I are delighted to assist you.

Here's to a healthier, safer way to pure drinking water.

My best regards,
MD, BRITA INDIA

About BRITA



WATER PURIFIERS

BRITA was founded in 1966 by Heinz Hankammer in Taunusstein, Germany. Today with a global turnover of over 500 million Euros (Business 2017), the BRITA Group is one of the leading companies engaged in the optimization of drinking water. Established 50 years ago, today BRITA develops, produces and distributes a broad range of innovative solutions for optimizing drinking water from water filter pitchers, dispensers, under-the-sink purification systems to BRITA Integrated Solutions for small and large electrical appliances.

BRITA invests heavily in research and innovation to deliver newer, better and simpler solutions for drinking water requirements. BRITA water purifiers have an advanced [100% RO+UV purification process with Pureshield™ Technology*](#) and [Alkatron® Mineralizer](#) to give 99.99% bacteria and virus free safe and pure drinking water while saving up to 100% more water compared to water purifiers with 25% recovery.

With a new range of water purifiers specifically designed to handle India's complex drinking water conditions, BRITA is all set to change the way India drinks water.

Note: The word BRITA used further in this manual includes BRITA GmbH and all its subsidiaries worldwide including BRITA India Water Solutions Pvt. Ltd.

** Applicable only on Mypure Max 7 & Mypure Max 6.*

01 Pre-instruction Literature

Thank you for being a proud owner of a BRITA water purifier.

On Receipt

It is our policy to make sure every order you place, is in safe hands. This product shipment has been thoroughly checked, packed and quality certified before leaving our plant.

Visible Loss or Damage

If any of the goods on the bill of Lading or Express are damaged or not the right quality, please don't accept them. Make sure you call BRITA customer care at **1800 2585 710 / +91 89291 45710** and inform.

Concealed Loss or Damage

When a shipment has been delivered to you in a good condition, but upon opening the container, you realise there is damage due to transit, please inform the BRITA representative immediately, who will arrange for a pick-up of the product from your location.

About this manual

This manual is a guide to good practice for operating, and to serve as a periodic manual, of the BRITA Mypure Max water purifier. This manual does not contain the full servicing procedures necessary for continued successful operation of this product. The services of a BRITA Authorized Service Technician should be engaged periodically.

Do not operate anything without reading this manual.

Please follow instructions in this manual to ensure personal safety and proper operation of this product. BRITA undertakes no liability for installation or servicing performed by any unauthorized personnel. Always install, operate, inspect and maintain this product in accordance with all applicable standards.

Please keep this manual handy for future reference.

02 General Instructions

These instructions have been written as a broad brief on the installation and the operation of your BRITA water purifier. BRITA water purifier should be installed by an authorized technician only.

1. Please read the operating and safety instruction provided in the manual carefully and adhere to these all the time. Thereafter, inspect the BRITA water purifier and its component parts for possible damage. If you detect any damage in your BRITA water purifier, Please contact:

Customer Care Centre: 1800 2585 710 / +91 89291 45710

2. Verify that the voltage being supplied corresponds to that which is mentioned in the manual.

NOTE: *This manual refers to the three models BRITA Mypure Max 7, BRITA Mypure Max 6 and BRITA Mypure Max 5. Please refer to the illustration corresponding to the product purchased.*

03 Introduction

All you need to know about the BRITA water purifier.

BRITA water purifier brings advanced technology and German engineering expertise to the purification process. It uses 100% RO+UV technology, one of the most effective processes available for pure and safe drinking water. BRITA water purifier has multistage purification process which removes the excess Total Dissolved Solids (TDS) and ensures that you get pure water.

Why is water purification important?

Water purification is essential because there are several harmful contaminants present in your water due to rapid urbanisation and speedy industrial growth. Below is a list of some of the harmful contaminants found in water which if consumed can cause serious damage to human health.

- **TDS (Total Dissolved Solids) like Nitrates, Chlorides, Sulphates etc.**
- **Pesticides and VOC (Volatile Organic Compounds)**
- **Heavy metals like Mercury, Arsenic, Lead, Chromium, Cadmium etc.**
- **Microorganisms such as pathogenic Bacteria, Virus, Protozoa and Cysts.**

BRITA water purifier removes excessive TDS (Total Dissolved Solids), reduces heavy metals, removes pathogens, infuses minerals in water and balances the pH value of water. This ensures you get safe, pure and great tasting drinking water.

BRITA Range of Water Purifiers

Mypure Max Series



BRITA Mypure Max 5



BRITA Mypure Max 6



BRITA Mypure Max 7

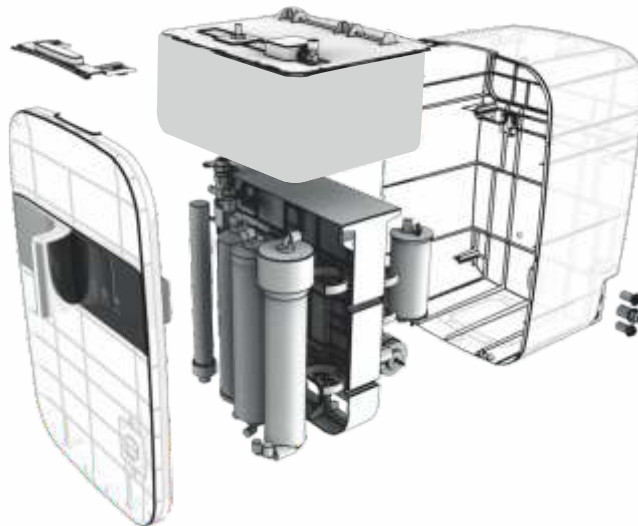

Exploded View of Mypure Max 7

04 Working of the Water Purifier

How does the BRITA water purifier work?

BRITA water purifier has a **multistage purification process**, where 100% of the water is passed through the various stages and then progressively filtered. The purified water is stored in the inbuilt storage tank.

- 1 Pre Filter** *(optional for Max 5 & Max 6)*
The Pre Filter is used to remove physical contaminants such as dirt, dust, soil particles and turbidity present in the water. This also improves the life of the other filters.
- 2 Pre Carbon Filter**
The Pre Carbon Filter uses activated carbon that has a high adsorption capacity. This removes harmful chemicals like pesticides, volatile organic compounds and residual chlorine in the water. It also adsorbs bad taste and odour from water.
- 3 Sediment Filter**
The Sediment Filter is used to remove fine and coarse physical contaminants present in the water. This improves the life and efficiency of the RO membrane.
- 4 Anti-scalant Filter** *(applicable on Max 6 & Max 7)*
The Anti-scalant Filter reduces the limescale deposits on the RO membrane increasing the lifespan of the water purifier.

5

RO Membrane

The RO Membrane is the heart of the RO + UV water purifier and it removes total dissolved solids (nitrates, chlorides, hardness etc.), heavy metals, microbial contaminants etc. BRITA water purifiers use best-in-class 3000 TDS RO membrane (applicable for Max 7 & 6) and high performance 2000 TDS RO membrane (applicable for Max 5) to ensure pure and safe water always. The 3000 TDS best-in-class RO membrane is integral to Pureshield™ Technology which along with the anti-scalant helps save up to 100% more water*.

6

Post Carbon Filter + Alkatron® Mineralizer

This adds essential minerals such as calcium, potassium and anti-oxidants in water. Also adds alkaline ions for pH balanced** healthy and tasty water.

7

UV Filter

The UV (Ultra Violet) Filter provides additional protection by using ultraviolet radiation to deactivate disease-causing organisms, thereby giving pure and safe water always.

*Compared to conventional RO purifiers with a recovery of 25%

**pH balance depends on input water condition

Mypure Max 5

5 Stage Purification Process

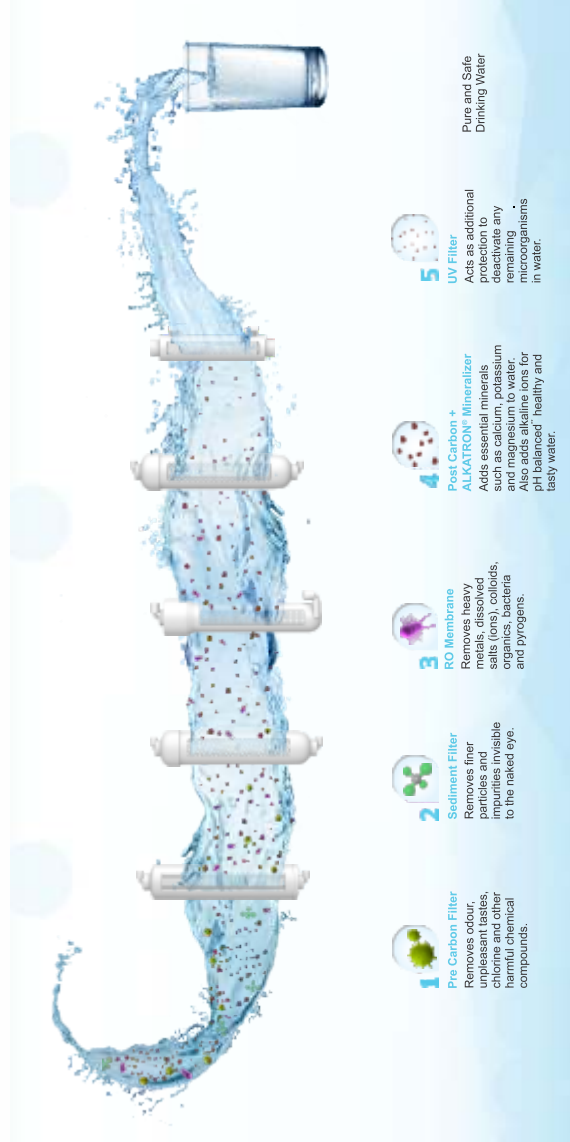

For creative visualisation only

pH balance depends on input water condition

Mypure Max 6

6 Stage Purification Process

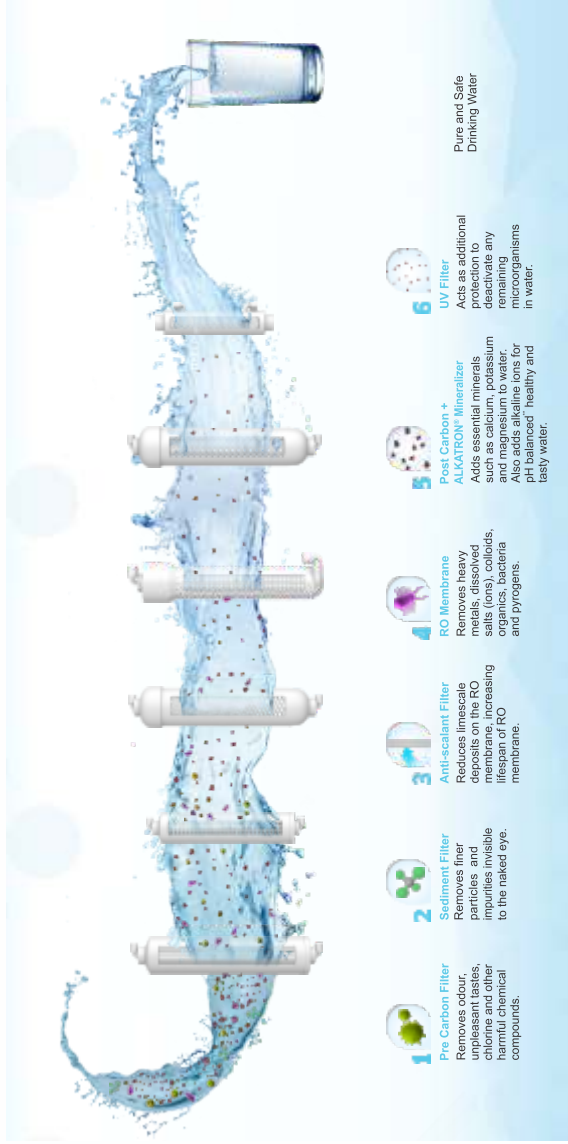

For creative visualisation only

pH balance depends on input water condition

Mypure Max 7

7 Stage Purification Process

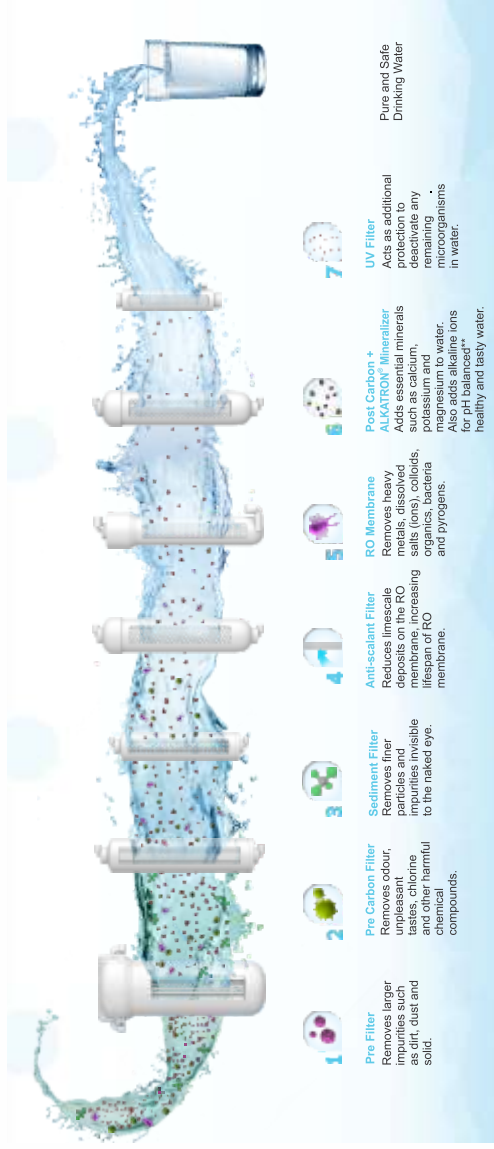

For creative visualisation only

¹ pH balance depends on input water condition

05 Product Overview

Mypure Max 5

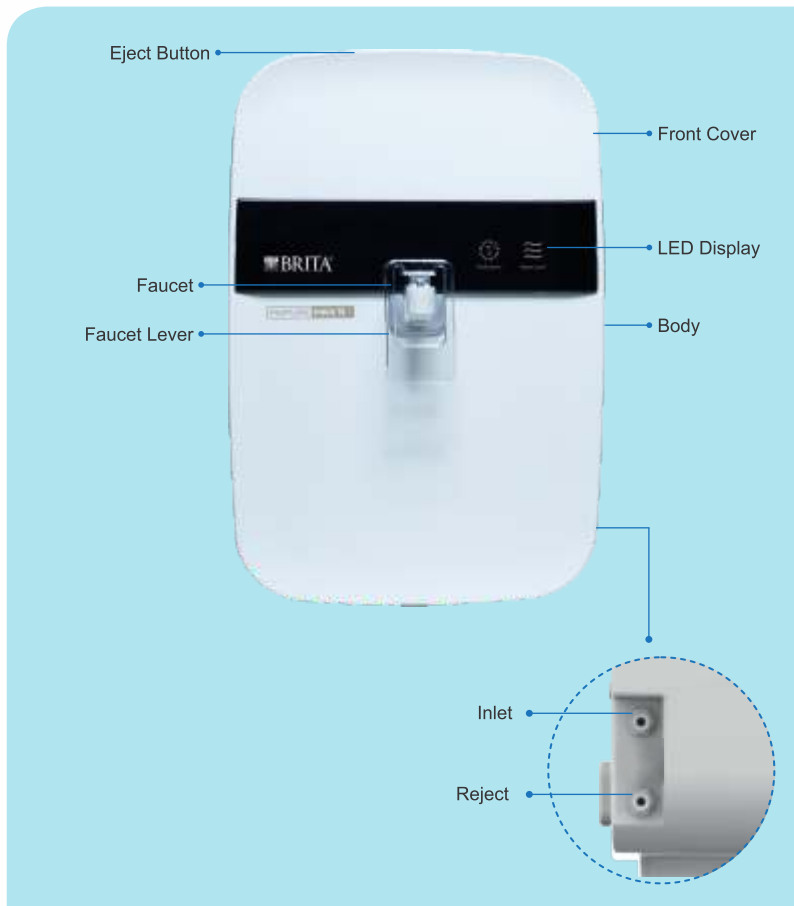

Mypure Max 6



Mypure Max 7

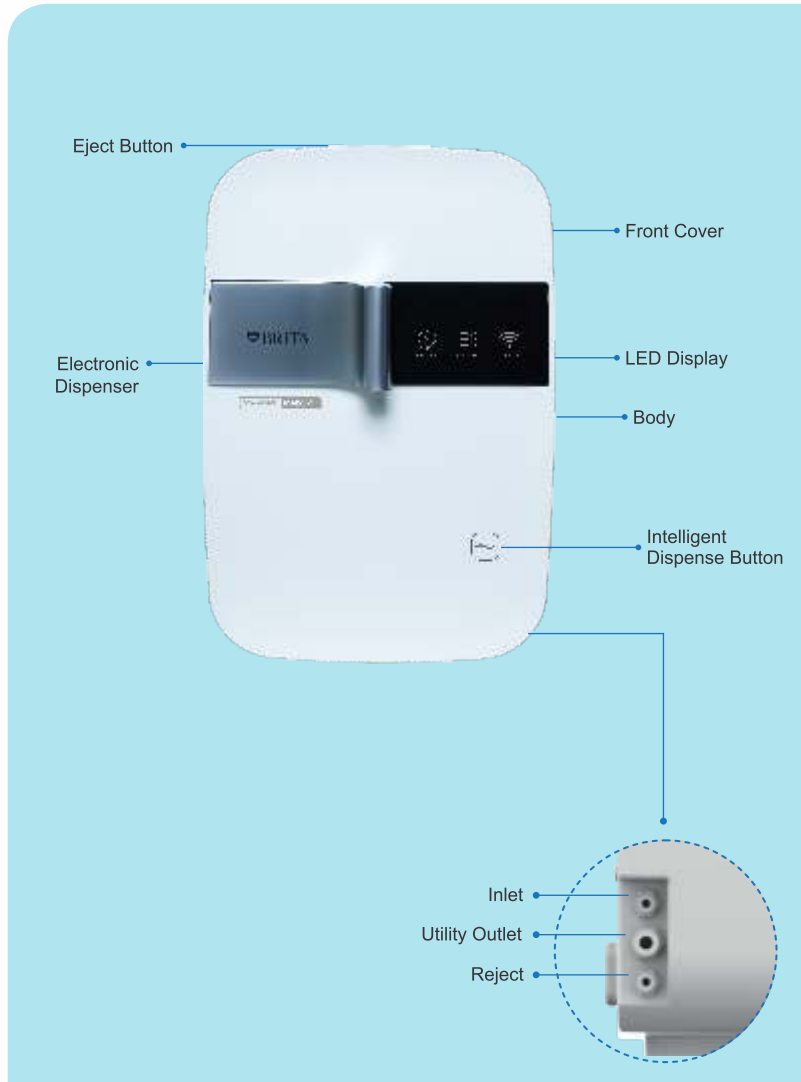

06 Function of Indicators (LED Display)

LED Display On Purifier

Mypure Max 5 & 6

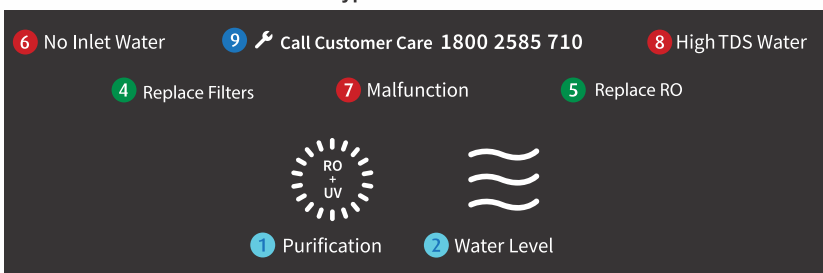

Mypure Max 7

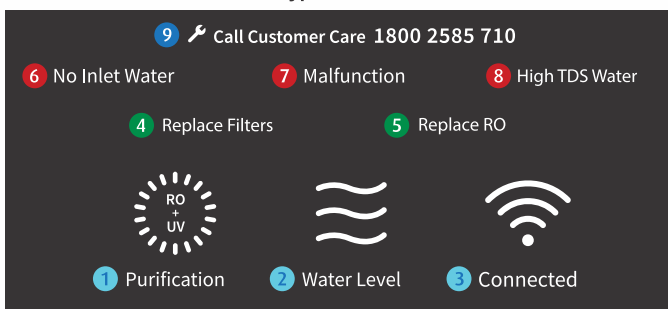

- 1 Purification Indicator
- 2 Water Level Indicator
- 3 Wi-Fi Connectivity Indicator
- 4 Replace Filters Indicator
- 5 Replace RO Indicator
- 6 No Inlet Water Indicator
- 7 Malfunction Indicator
- 8 High TDS Water Indicator
- 9 Call Customer Care Indicator



Purification Process Indicator:

The indicator is displayed intermittently when the purification process is on. Once the purification process is complete and the tank is full, the indicator will be completely illuminated.



Water Level Indicator:

When the purification process is on (and the purified water is getting filled in the tank), the indicator shows the progressive water tank filling indication. Once the tank is full, the indicator will be completely illuminated.



Wi-Fi Connectivity Indicator:

(only for Mypure Max 7)

- When the product is connected to the app via the Wi-Fi, the Wi-Fi indicator is lit.
- When the Wi-Fi connection to the product is lost, the panel displays "Not Connected".



Filter Indicator:

- Displays intermittently when the filters have only 10% life remaining.
- Displays continuously when the filters need replacement.



RO Membrane Indicator:

- Displays intermittently when the RO Membrane has only 10% life remaining.
- Displays continuously when the RO Membrane needs replacement and the purifier will stop the purification process.

Error Messages:

No Inlet Water

No Inlet Water Indicator:

Displayed when there is no inlet water into the water purifier. Check feedwater supply to the water purifier. If the problem persists, switch off the water purifier and call Customer Care Centre.

Malfunction

Malfunction Indicator:

Displayed when there is a malfunction in the water purifier. Switch off the water purifier and call Customer Care Centre.

High TDS Water

High TDS Water Indicator:

Displayed when the TDS value is higher than the drinking water standard (above 500 TDS). Switch off the water purifier and call Customer Care Centre.

Call Customer Care:

 Call Customer Care 1800 2585 710

Call Customer Care Indicator

07 Working Diagrams

Electrical Diagram - Mypure Max 5 & Mypure Max 6

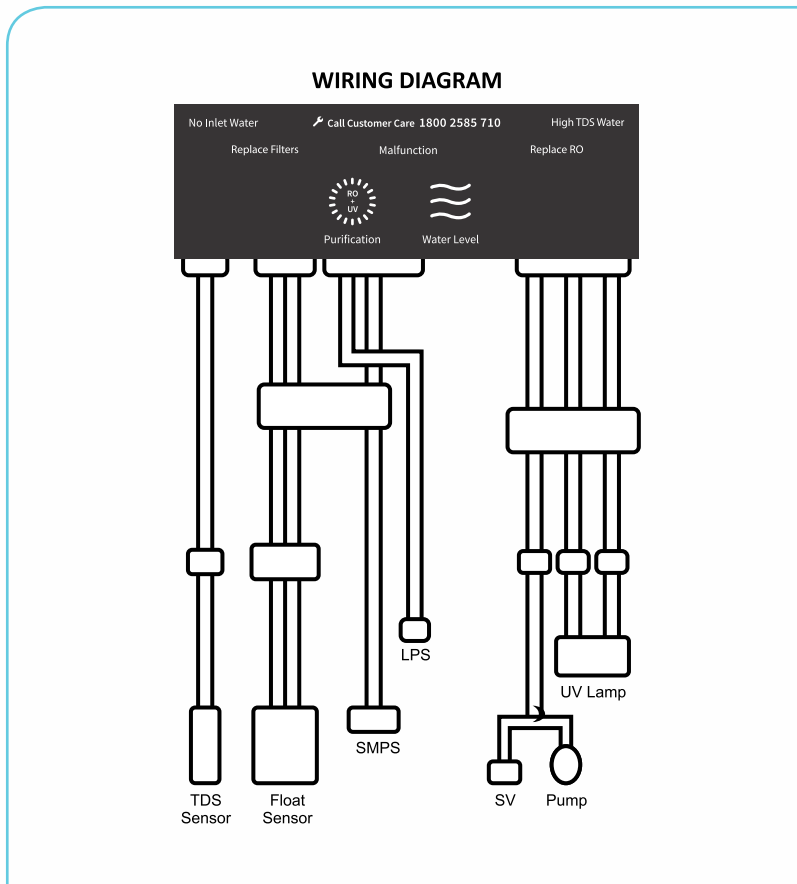

Electrical Diagram - Mypure Max 7

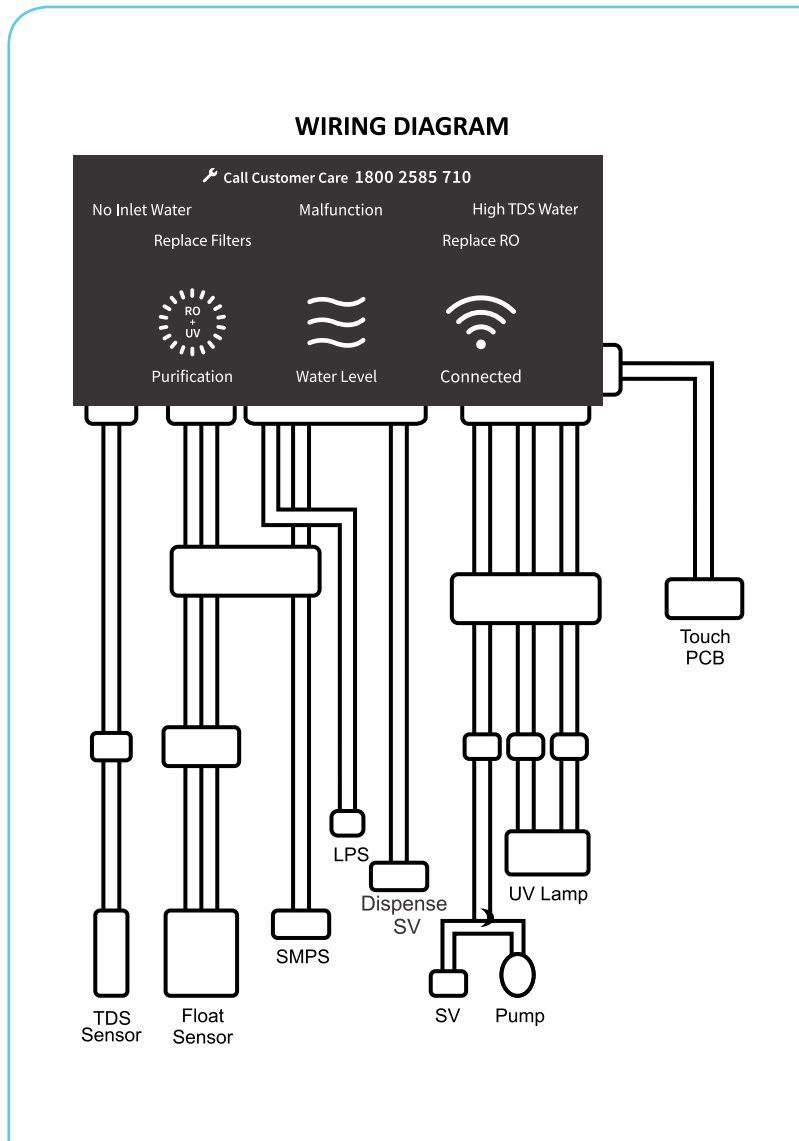

Mypure Max 5

Water Flow Diagram

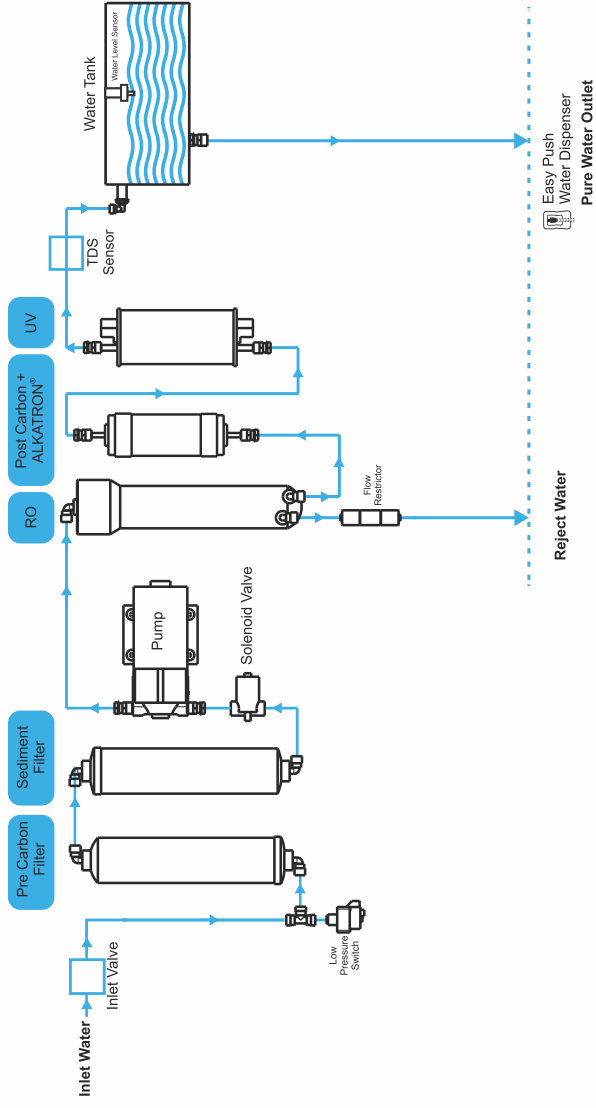

MyPure Max 6

Water Flow Diagram

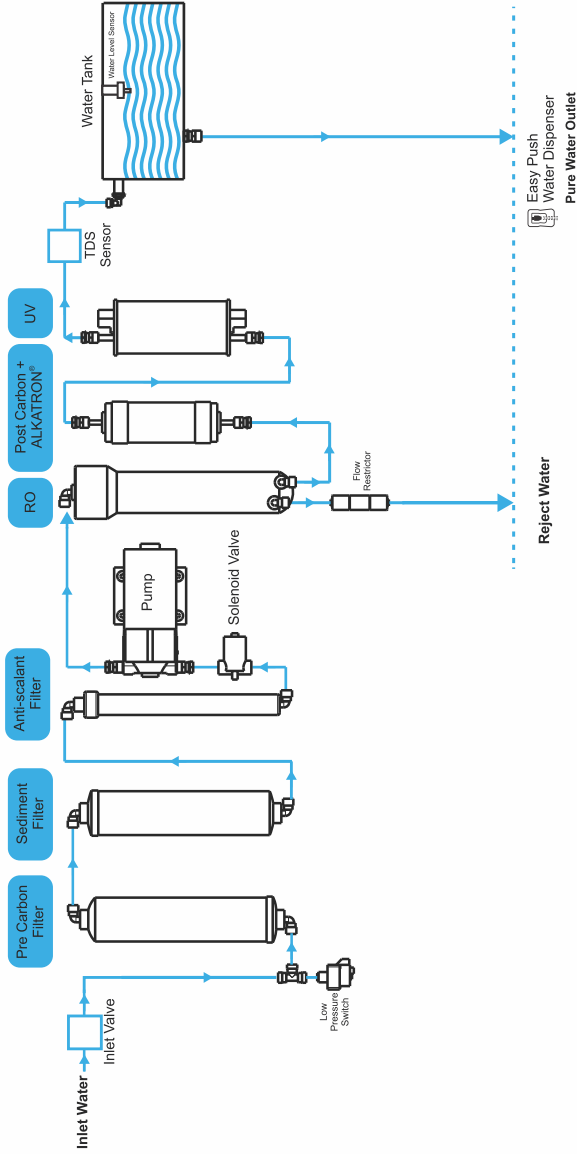

Mypure Max 7

Water Flow Diagram

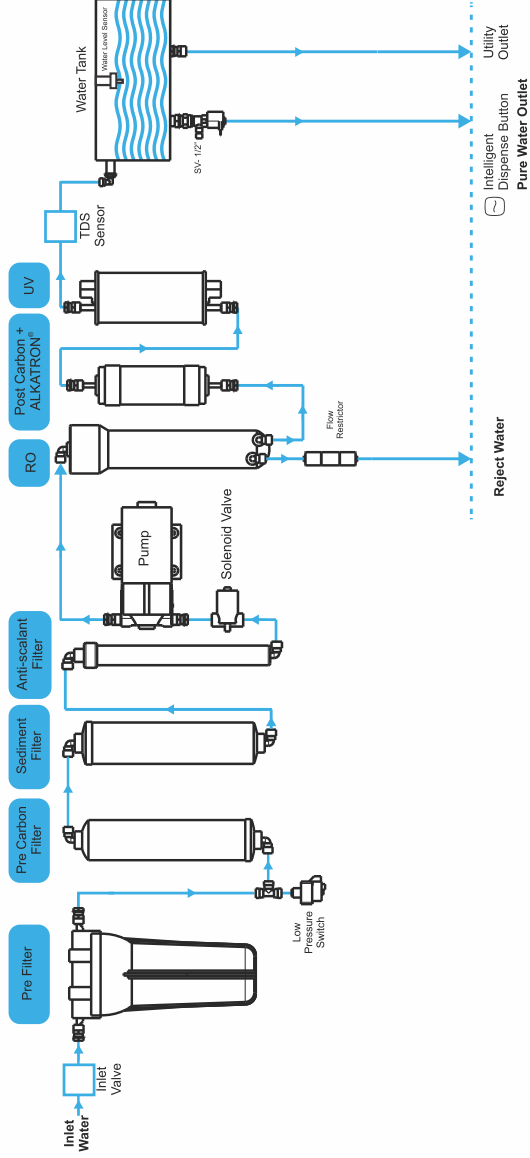

08 Safety Precautions

(Applicable for Mypure Max 5, 6 & 7)

Electrical Safety

This product is designed with the highest safety standards. However, please follow the instructions provided in this manual.

The power plug should be connected to the grounded 230V outlet.

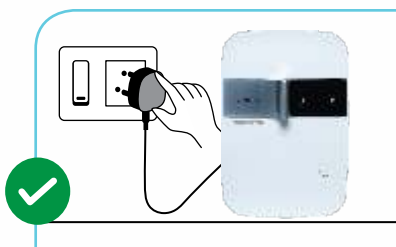

DO NOT pull out or touch the power plug with wet hands to avoid electrical shock.

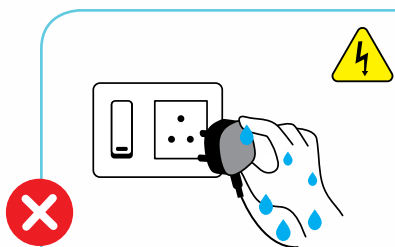

Installation

Install the product while keeping it away from direct sunlight.

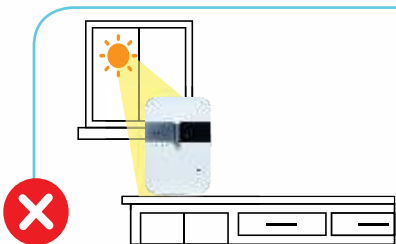

Make sure that the feed water is tested before installation. **DO NOT** install the product if the TDS and hardness are more than the recommended 'Feed Water Conditions' (Mentioned on Pg. 33).

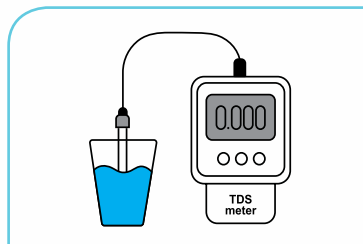

Product should be installed only by a **BRITA Authorized Service Technician**. Cleaning the filters or replacing any part should also be done only by a BRITA Authorized Service Technician.

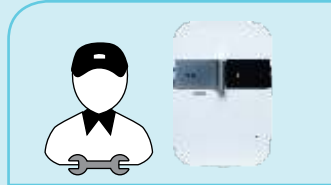

Caution:

DO NOT place heavy objects on the product.

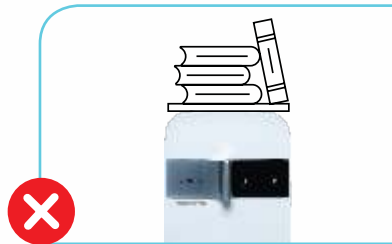

DO NOT open the purifier



NOTE: Adult supervision is recommended when the product is used by or is near children.

09 How to Use the Water Purifier

(Applicable for Mypure Max 5, 6, 7)

1) Turn ON the water connection through the inlet valve.

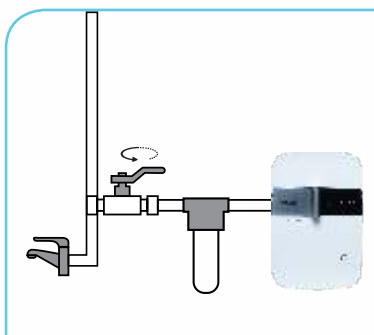

2) Switch ON the power supply.

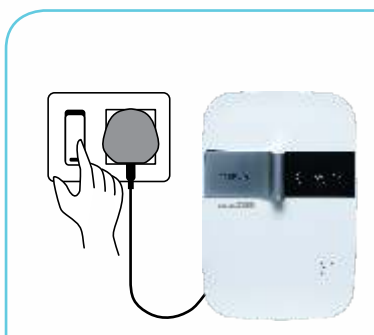

10 How to Dispense Water

Mypure Max 5 & Mypure Max 6

To dispense water from the storage tank, push and hold the water faucet lever. To stop the water flow, release the water faucet lever. You can also pull up the water faucet lever to get the continuous flow of water and pull down the lever to stop the water flow.



Mypure Max 7

To dispense water from the water purifier, touch the intelligent dispense button for a second, (this system ensures that the water does not dispense while wiping the water purifier for cleaning purpose). To stop the water flow touch the intelligent dispense button again.



11 Draining the Drip Tray* (Accessory)

A removable Drip Tray* (Accessory) can be bought along with the product. In case of an overflow, the water gets collected in the Drip Tray. To drain the water from the Drip Tray, follow the instructions below.

Remove the Drip Tray* by pulling it forward.



Remove the Drip Tray* cover by pulling upward and then draining it completely.



Clean the Drip Tray* container by holding it under running water.

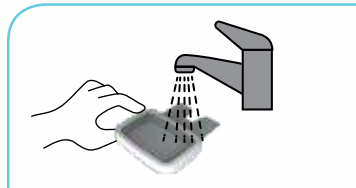

Re-attach the Drip Tray* into the purifier.



**Drip Tray is suitable for counter top use only.
Available for purchase through BRITA CUSTOMER CARE CENTRE at additional cost.*

12 How to Maintain the Water Purifier

(Applicable for Mypure Max 5, 6, 7)

DO NOT splash water directly on the product. Do not clean with benzene, pesticides, thinner, alcohol etc. Instead use a soft and dry cloth to clean the purifier.



Use BRITA genuine filters and spares only for optimal performance of the purifier. These genuine filters and spares designed by BRITA understand the specification of the product thereby ensuring they fit perfectly.



Replace filters regularly according to the Replace Filter/Replace RO indications. This must be done by a [BRITA Authorized Service Technician](#), who is rigorously trained and well equipped to ensure a hassle free service experience.

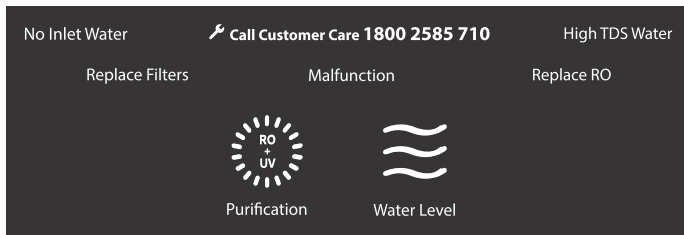
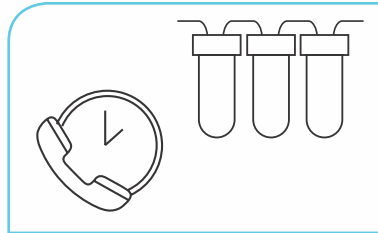

Mypure Max 5 & 6

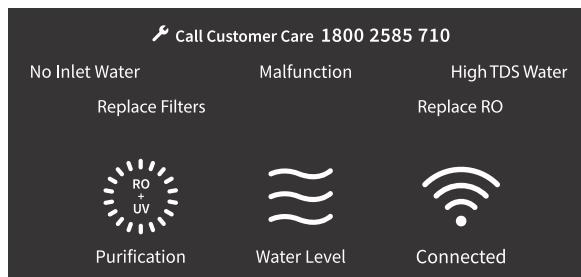

Mypure Max 7

13 How to connect the Water Purifier and the App via Wi-Fi (only for Mypure Max 7)

German Engineered for your peace of mind: The exclusive BRITA Mypure Max App indicates real-time performance of the water purifier and gives you the assurance of being in the right hands – 24/7.

BRITA Mypure Max App is available for download on both iOS and Android platforms (search key word BRITA Mypure Max).

Configuration steps

1. Ensure that the BRITA Mypure Max water purifier is connected to a power supply and that the power supply is switched ON.
2. Download the BRITA Mypure Max App from the IOS or Android Store.
3. Open the App.
4. Click on “**Get Started**” to proceed to configuration.
5. Click on “**Connect to BRITA Network**” to join BRITA network.
6. Choose “**Configure Wi-Fi**” and select your preferred home Wi-Fi network.
7. Enter password of your selected Wi-Fi network and click on “**save**” to connect the water purifier to the App.
8. Upon the successful configuration click on “Proceed”. Now your water purifier is connected to the App and the Wi-Fi symbol in the water purifier display will start glowing and show “Connected” (see reference below). Note: This is a one-time procedure need not to be repeated every time.

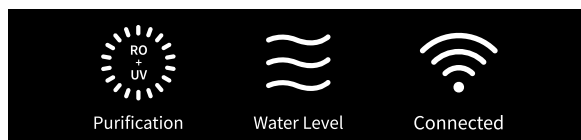

9. In case of unsuccessful configuration the display will show 'Not Connected', Please repeat steps 5, 6 and 7 to reconfigure.

For further clarification please call our Customer Care at **1800 2585 710 / +91 89291 45710** or visit **www.brita.in**

Installation of the BRITA Mypure Max app on your mobile phone will be supported by a BRITA Authorized Service Technician at the time of installation of your water purifier

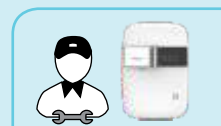

14 Troubleshooting

Your BRITA water purifier might not function if used incorrectly. This does not mean the product is faulty. For instances like these, please follow the steps given below to resolve the problem without outside help. If the problem still persists, please call the Customer Care Centre: 1800 2585 710 / +91 89291 45710 immediately.

PROBLEMS	CHECK-UP	SOLUTIONS
Change in water taste	Has the purified water been stored in the tank for a long time?	Drain the stored water from the storage tank through the faucet
	Filters may require replacement. Check if the "Replace Filters" or "Replace RO" indicator is illuminated	Call Customer Care Centre for replacement
	Has the raw water quality changed?	Call Customer Care Centre
	Check if the water has stopped flowing through the reject tube	Switch OFF the water purifier and call Customer Care Centre
Decreased flow of purified water	Check whether the tap/ball valve is closed	Open the tap/ball valve if it is closed
	RO membrane/filters may be clogged or damaged	Call Customer Care Centre for filters replacement

Customer care Centre: 1800 2585 710 / +91 89291 45710

Less/No reject water	Check if the reject water tube is bent	Clear the bend in the reject water tube
	Check if the reject water tube is blocked	Switch OFF the water purifier and call Customer Care Centre
Less/No purified water	Check whether there is water supply to the tap	If not, take the help of a plumber to set it right
	Check whether the tap/ball valve is closed	Open the tap/ball valve
	Check if the “Replace Filters” or “Replace RO” indicator is illuminated	Call Customer Care Centre for filters replacement
	None of the above	Call Customer Care Centre
Water not dispensing when button is pressed	Check whether power supply is switched ON	If power supply is switched ON and there is still no water, call the Customer Care Centre

15 Technical Specifications

Model	BRITA Mypure Max 7, 6, 5
Product Dimension (H x W x D)	540 mm x 360 mm x 275 mm (without faucet)
Net Weight	10.4 kg (approx.)
Gross Weight	12.5 kg (approx.)
Flow Rate*	Up to 15 litres per hour
Storage Tank Capacity	7 litres
Purification Technology	RO (Reverse Osmosis) + UV (Ultra Violet)
7 Stage Purification Technology	Pre Filter (optional for Max 5 & 6) + Pre Carbon Filter + Sediment Filter + Anti-scalant Filter (applicable for Max 6 & 7) + RO Membrane + Post Carbon ALKATRON® Mineralizer + UV Filter
Membrane Type	Thin film composite RO membrane
Material of construction	Food safe, non-toxic, engineering grade plastic
Pump Type	Diaphragm pump, 24VDC, 1.2 amps at 80 psi
Input Voltage	230 VAC, 50 Hz
Power Rating (Max.)	60 Watts
Pressure Rating ***	7 psi to 30 psi
% Recovery**	Up to 50% ^ for Max 6 and Max 7 Up to 30% ^ for Max 5
TDS reduction **	Up to 95% (approx.)

* Flow rate depends on variable factors such as feed water pressure, feed water characteristics and condition of the RO membrane and filters.

** Recovery and TDS reduction percentages also depend on variable factors such as life and condition of the RO membrane and filters, feed water pressure and feed water characteristics.

*** If input pressure exceeds 30 psi, a pressure reducing valve needs to be installed at the feed line. If the pressure is lower than 7 psi, a booster pump needs to be installed. Ensure you buy them from BRITA Authorized Service Technician.

^ As tested under lab conditions with input water TDS of 750 ppm, water temperature of 27°C and feed pressure of 20 psi.

Recommended input feed water quality for the optimum performance of your product

RECOMMENDED FEED WATER QUALITY	
Parameter	Limits
Total Dissolved Solids (TDS)	Up to 2000 ppm for Max 5 Up to 3000 ppm for Max 6 and Max 7
Total Hardness	Up to 500 ppm
Turbidity	Up to 5 NTU
Iron	0.3 ppm (max.)
Feed Water Pressure	7 psi to 30 psi
Feed Water Temperature	5°C to 45°C

16 Frequently Asked Questions

1. What is 100% RO+UV?

In ordinary RO+UV water purifiers, some amount of water bypasses the RO membrane. With this, heavy metals, unwanted salts and pesticides also come through. In BRITA Mypure Max, 100% of the water is passed through the RO membrane, ensuring water is pure and healthy.

2. What is BRITA Mypure Max 7 / 6 / 5?

BRITA Mypure Max 7 / 6 / 5 has an advanced multi stage RO+UV water purifier. It is 100% RO i.e there is no bypass of water to ensure maximum purity.

3. What is Pureshield™ Technology? (Applicable only for Mypure Max 7 and 6)

Pureshield™ Technology is a combination of high end membrane, anti-scalant and regulated water flow synchronized to heighten purification performance. The anti-scalant removes limescale deposits, enabling the RO membrane to work effectively for a longer period of time. By saving up to 100% more water compared to conventional RO purifiers with a recovery of 25%, Pureshield™ Technology helps BRITA stay true to its philosophy of providing sustainable solutions.

4. What is ALKATRON®?

Alkatron® Mineralizer infuses water with alkaline minerals such as potassium, calcium, magnesium that enrich and give water an ideal pH balance**.

5. What are the stages of filtration in BRITA Mypure Max?

BRITA Mypure Max purification stages are Pre Filter (optional in 5 and 6) + Pre Carbon Filter + Sediment Filter + Anti-scalant Filter (applicable for 6 and 7) + RO Membrane + Post Carbon ALKATRON® Mineralizer + UV Filter.

6. Does it replenish water in the minerals?

Yes, BRITA Mypure Max 7 / 6 / 5 has Alkatron® Mineralizer which not only add essential minerals in water, it also balances the pH value** in the water.

***pH balance depends on input water condition.*

7. What is the storage capacity of BRITA Mypure Max 7 / 6 / 5?

BRITA Mypure Max 7 / 6 / 5 has a total storage capacity of 7 litres.

8. What is the purification flow rate of BRITA Mypure Max 7 / 6 / 5?

Flow rate is up to 15 litres per hour, however the purification capacity also depends on water quality, condition of filters and the RO membrane.

9. Does it have Pre Filter? Is it free?

Yes, BRITA Mypure Max 7 comes with a Pre Filter which is a part of the product. For BRITA Mypure Max 6 / Mypure Max 5 you can buy the Pre Filter from BRITA Customer Care Centre. Services of a BRITA Authorized Service technician are at an additional cost.

10. What alerts do BRITA Mypure Max 7 / 6 / 5 have?

BRITA Mypure Max 7 / 6 / 5 has advanced alerts to change the filters and error messages on the LED display in the machine.

11. When does BRITA Mypure Max 7 / 6 / 5 indicate a filter replacement?

Displays intermittently “Replace Filters” or “Replace RO” when the consumption of filter life is at 90%. When the filter life consumption is at 100% the water purifier continuously displays “Replace Filters” or “Replace RO” alert on the LED panel.

12. What is the digital display in BRITA Mypure Max 7 / 6 / 5?

Digital display in BRITA Mypure Max 7 / 6 / 5 indicates

- 1) Filter Replacement alerts
- 2) Water Level indicator
- 3) Wi-Fi Connectivity indicator (applicable for BRITA Mypure Max 7)
- 4) Purification Process indicator
- 5) High TDS indicator

13. Can BRITA Mypure Max 7 / 6 / 5 be mounted on the wall or be placed on the counter?

Yes, BRITA Mypure max 7 / 6 / 5 can be mounted on the wall or placed on the counter.

For further details, please visit www.brita.in

17 Recommended Uses Of Waste Water

Although the rejected water has a high concentration of TDS (Total Dissolved Solids) and hardness, it can be used for the following:

1. For watering the garden and plants.
2. For mopping and cleaning the floors.

NOTE: Please consult a BRITA Customer Care Centre: 1800 2585 710 / +91 89291 45710 before using this water.

18 Recommended Filter Change

All filters should be bought from **BRITA Customer Care Centre** only and installed by **BRITA Authorized Service Technician** only.

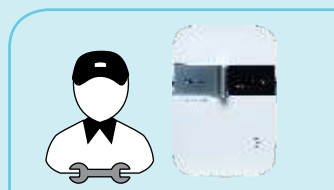

19 Warranty Policy

BRITA India Water Solutions Private Limited (“BRITA”) warranty obligations for this water purifier are limited to the terms set forth below:

POLICY DETAILS

BRITA warrants this water purifier to be free from any defects in material, operation, and workmanship for the specific warranty period which is limited to fifteen (15) months from the date of purchase or twelve (12) months from the date of installation whichever is earlier. However, it does not warrant that any BRITA product will work uninterrupted or error-free. The warranty shall be limited only to defects in the product which occur under the conditions of normal operation of the product and its proper and prescribed use as per this manual and does not cover BRITA water purifier which has been misused, altered, neglected, handled carelessly, or damaged due to improper cleaning or unauthorized repairs. Inspection and test report of BRITA’s office / service centre / authorized dealer will be final and binding under the warranty for determining defects, repairs / alterations required or carried out or certifying working of the product thereafter.

If a defect arises, the customer will notify BRITA Authorized Service Technician of the same or call on the Customer Care helpline at 1800 2585 710 / +91 89291 45710 to raise a claim. If a valid claim is received within the warranty period, by BRITA, BRITA shall

- Repair or replace the product at no charge; or
- Exchange the product with a new product which has been manufactured from new or serviceable used parts and is functionally equivalent to the original product.

BRITA may REPAIR or REPLACE product –

1. With parts which are equivalent in performance to the products being repaired or replaced but which may have been subject to prior use.

2. With parts which may contain remanufactured parts equivalent to new in performance or parts which have been subject to prior incidental use, or

3. With parts that are equivalent in function to an original part that has been discontinued.

4. Dead on Arrival - In case of any unit being non-functional (not switching on) on arrival, the same shall be replaced by BRITA on registration of the complaint placed by the customer with the BRITA Customer Care helpline.

5. BRITA warrants replacement products or parts provided under this warranty against defects in materials and workmanship from the date of replacement or repair within 90 days or for the remaining portion of the original product's warranty, whichever provides longer cover for the customer. When a product or part is exchanged, any replacement item becomes the customer's property and the replaced (defective) item becomes BRITA's property. The warranty provided under this user manual is valid only within BRITA Service Network Coverage.

6. The customer shall notify BRITA about any defects noticed and give BRITA or its representative opportunity to inspect, test and rectify. If necessary, the customer shall handover the product to the Authorized Service Technician or BRITA Customer Care Centre.

7. BRITA or its representative will be entitled to retain any defective parts replaced under warranty on free of charge basis.

8. The warranty obligations on BRITA under this user manual is limited only to the original purchaser of the BRITA water purifier. BRITA shall not in any manner, either directly or indirectly, be liable to provide warranty service(s) to a third-party to whom ownership of the BRITA water purifier has been transferred from the original purchaser. In such cases, the warranty obligations of BRITA under this user manual, shall be void.

9. The customer is required to provide the original invoice copy or duly stamped warranty card at the time of any repair work being done by Authorized Service Technician. Date of the original invoice determines the date of original purchase.

10. However, if the customer is unable to produce the original invoice, customer data with BRITA will be used to determine the date of original purchase and will be treated as final. If details are not found from BRITA's records, manufacturing warranty as per the product serial number will be used as date of original purchase.

WARRANTY COVERAGE

All electrical, functional parts are warranted for one (1) year from the date of original invoice date.

The RO Membrane will be covered for any material damage under warranty for one (1) year from date of purchase. The RO membrane will also be covered under warranty for one (1) year if -

- Input water TDS is <2000 TDS for Max 5 and <3000 for Max 6 & 7.
- Hardness of raw water is less than 500 ppm.

The warranty is issued at Bengaluru and courts at Bengaluru shall have exclusive jurisdiction over matters that cover or flowing from this warranty.

PREVENTIVE MAINTENANCE SERVICE (PM)

During the period of warranty, a total of three (3) free preventive maintenance services will be offered to all customers. The preventive maintenance services will be provided once every four months. During this preventive maintenance, if any part is required to be replaced but not covered under this warranty, the cost of it will have to be paid by the customer.

EXCLUSIONS

Warranty Does Not Cover:

- Accident, abuse, misuse, misapplication;
- Improper or inadequate maintenance or usage by the customer;
- Repair, maintenance, modification by unauthorized personnel;
- Operation contrary to published operating instructions for the product;
- If any BRITA serial number has been removed or defaced;
- Warranty does not cover any accessories provided locally by dealer or purchased by the customer;
- Any filter except the RO Membrane;
- Plastic parts, external booster pump, pressure reducing valve, UV lamp;
- If defect or fault is caused or occurred due to improper installation by the customer or not installed as per BRITA guidelines specified in product user manual;

- If failure or damage due to plumbing or other arrangements like, usage of pressure pump, extension of power supply board, non-compatible power socket etc. connected to product. With regard to repairing the existing worn-out/defective part(s) or replacing the same and ascertaining the presence of above circumstances, the decision of BRITA shall be final. In any such event, BRITA will submit a prior estimate for approval of the work to be carried out at the rate prevailing at that time
- If damage is caused by pest infestation;
- If the input water emits pungent smell or is discolored;
- If product is used for commercial purpose, or such other exclusions as expressly set forth in this warranty statement;

LIMITATION OF IMPLIED WARRANTIES

1. No BRITA reseller, agent, or employee is authorized to make any modification, extension, or addition to this warranty terms and conditions.
2. Warranty is valid within BRITA Service Network* Coverage only. In case the customer moves to a non-coverage area, the customer needs to bring the product to nearby service network location. BRITA shall not be responsible for providing services to non-service network areas.
3. Notwithstanding anything contained in this warranty terms, BRITA shall not be liable in case of failure to provide services under this warranty in case of any force majeure event, i.e., due or attributable to any act of God, orders, restrictions or regulation of Government, Central or State, war working conditions, hostilities, riots, civil commotion, strike, lockout, labour trouble, explosion, insects, rodents or any other cause or circumstance of whatsoever nature beyond the control of BRITA.
4. The customer will have no claim under this warranty in respect of any personal injury, sickness, illness, death, property damage or consequential damages, arisen either directly or indirectly due to utilisation of product.
5. BRITA reserves the right to make design, service offerings & product changes or change the specification at any time without any obligation to prospective buyers or customers or owners of products previously sold.
6. Any implied warranty / conditions under applicable law, including but not limited to those regarding quality, fitness for purpose or merchantability or hereby specifically disclaimed and excluded by BRITA, unless otherwise provided in this manual.

** BRITA Service network coverage is limited to the municipal limits of the city it operates in. For the list of cities BRITA are present in, please visit www.brita.in*

POST WARRANTY

1. The customer may be offered a yearly annual maintenance contract (AMC) at the prevailing company rates and terms.
2. In case the customer does not wish to enter the service contract, the customer has the option of calling our Customer Care Centre and get the BRITA water purifier unit serviced on actual basis i.e. by paying the labour cost and spares needed to attend to that service or service call at the prevailing company rates. Such service* will be rendered by the company in towns or places where the company has its Customer Care Centre.
3. In case of product repair after warranty by Customer Care Centre, all expenses of transporting the goods to and from the Customer Care Centre shall be borne by the customer directly.
4. If, during such service, it is necessary for the Company or Customer Care Centre to replace or repair defective components or parts, the customer shall be required to pay for the same as per the company's prevailing price list.

** BRITA Service network coverage is limited to the municipal limits of the city it operates in. For the list of cities BRITA are present in, please visit www.brita.in*

BRITA Mypure Max Warranty Card

Invoice Number:

Dated:

Model:

Unit Serial Number:

Capacity:

Customer Name:

Address:

.....

.....

Phone:

Mobile:

Email:

Product Serial Number:

Mail: customercare@brita.in
Website: www.brita.in

BRITA Intellectual Property Rights



Pureshield™

Alkatron®

MYPURE MAX™

The logos indicated above are the trademark/intellectual properties of BRITA in India and other countries.

The ownership of, and all right, title, and interest in, all proprietary information, copyright, trademarks, trade names and logos (whether or not registrable and whether or not design rights subsist in them), inventions (whether patentable or not, and whether or not patent protection has been applied for or granted) and all other intellectual property throughout the world, in and for all languages, including but not limited to “BRITA”, “Pureshield”, “Alkatron” and “Mypure Max” used in this manual, including the contents of this manual, are properties of BRITA.

BRITA has the sole, full and unlimited right to use all of the intellectual properties without any claim or right by a third-party. No permission or licence has been granted under this manual to use any such intellectual property, including the trademark or service mark, whether in whole or part, or as a suffix or prefix, or in any other form, without the prior written consent of BRITA or its legal representatives (as the case may be). Any unauthorised use, publication, distribution (in either original or reproduced form) or reproduction of these intellectual properties, will result in penal action against the defaulting party.

Every effort has been made to ensure that the information in this manual is accurate. BRITA is not responsible for printing or clerical errors.

Copyright © 2019 BRITA India Water Solutions Private Limited. All rights reserved.



For Service and Maintenance or
any complaints/feedback, please contact
our customer care centre:

Call Centre number: 1800 2585 710 / +91 89291 45710

Mail : customercare@brita.in

Website : www.brita.in

BRITA India Water Solutions Private Limited
1st Floor, Retail Block, Green Heart Phase IV Mfar
Manyata Tech Park, Nagawara
Bangalore - 560 045



WATER PURIFIERS